

AD410 (G552)

This parts catalog includes MB No. 1 to 4

AD410 (G552)

PARTS CATALOG

This catalog gives the numbers and names of parts on this machine.

1.DUPLEX UNIT 1 (G552)	2
2.DUPLEX UNIT 2 (G552)	4
3.DUPLEX UNIT 3 (G552)	6
4.DUPLEX UNIT 4 (G552)	8
PARTS INDEX	11

June ,30 ' 2003

1.DUPLEX UNIT 1 (G552)

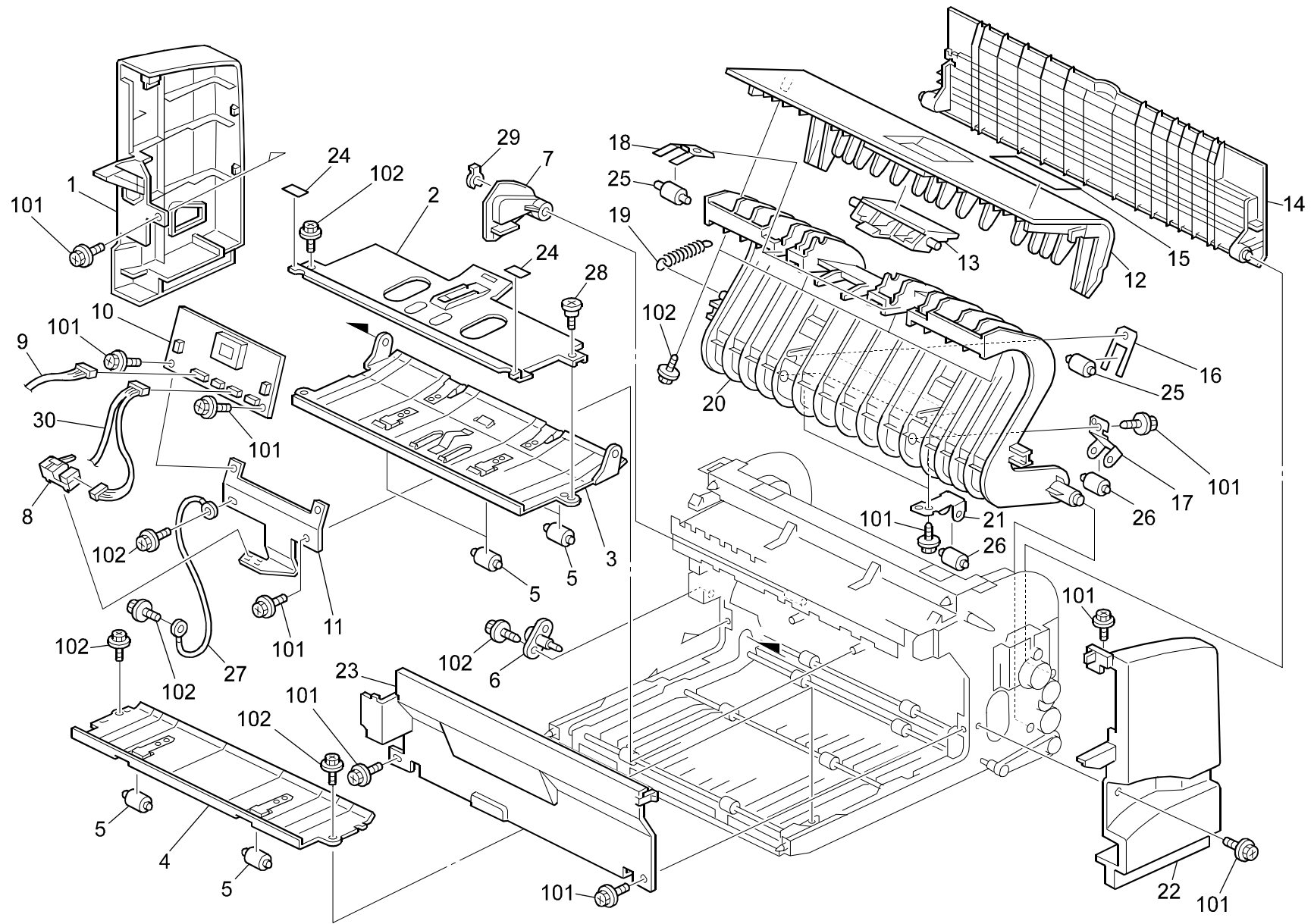

1.DUPLEX UNIT 1 (G552)

Index No.	Part No.	Description	Q'ty Per Assembly
1	G552 7389	Front Cover	1
2	G552 7235	Left Guide Cover	1
3	G552 7283	Left Guide Plate	1
4	G552 7328	Right Guide Plate	1
5	G552 7285	Driven Roller	6
6	G552 7364	Shaft	1
7	G552 7334	Release Lever	1
8	G552 7050	Photointerruptor	1
9	G552 7913	Harness	1
10	G552 7965	Main Control Board (CHN)	1
	G552 7931	X/O MB3	
10	G552 7971	Main Control Board (EU/NA) MB4 ADDED	1
11	G552 7025	Sensor Bracket	1
12	G552 7391	Upper Cover	1
13	G552 7344	Lever	1
14	G552 7343	Cover	1
15	G552 2300	Decal - Misfeed	1
16	G552 7366	Spring Plate - Vertical Transport	2
17	G552 7292	Spring Plate - Lower Vertical Transport	2
18	G552 7365	Spring Plate - Upper Vertical Transport	2
19	G552 7392	Cover Spring	1
20	G552 7356	Left Guide	1
21	G552 7293	Spring Plate - Driven	1
22	G552 7348	Rear Cover	1
23	G552 7303	Base Cover	1
24	G552 7013	Decal - Guide Plate	2
25	G552 7360	Driven Roller	4
26	G552 7354	Driven Roller	4
27	G552 7916	Grounding Wire Harness	1
28	AA14 3287	Stepped Screw - M3	1
29	5447 2681	Snap Ring	1
30	G552 7915	Entrance Sensor Harness	1

Index No.	Part No.	Description	Q'ty Per Assembly
101	0451 3006B	Tapping Screw - M3x6	
102	0450 3008B	Tapping Screw - M3x8	

2.DUPLEX UNIT 2 (G552)

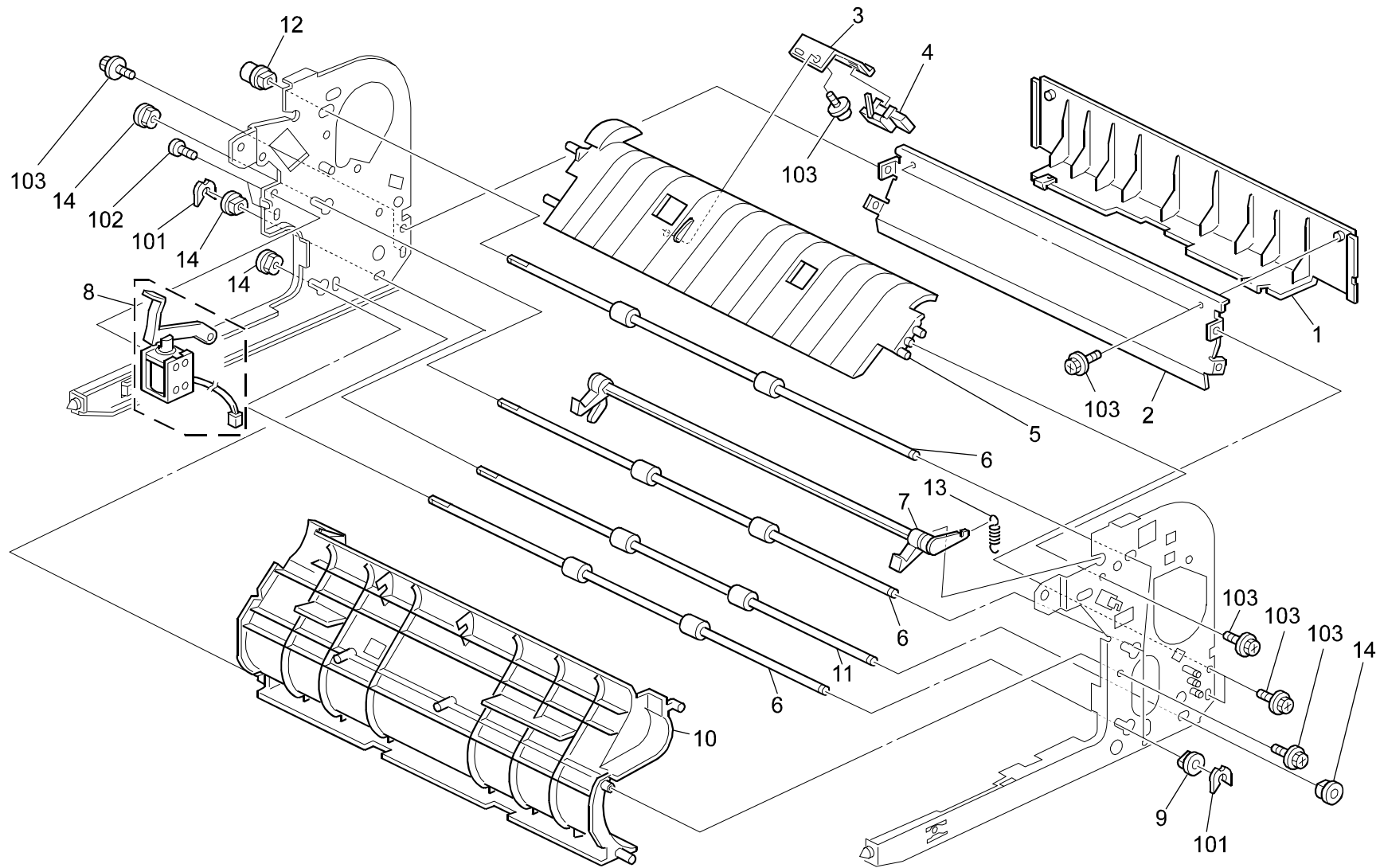

2.DUPLEX UNIT 2 (G552)

Index No.	Part No.	Description	Q'ty Per Assembly
1	G552 7387	Left Cover	1
2	G552 7130	Guide Plate	1
3	G552 7039	Upper Sensor Bracket	1
4	G552 7050	Photointerruptor	1
5	G552 7219	Upper Right Transport Guide Plate	1
6	G552 7066	Transport Roller	3
7	G552 7327	Fork Gate Release	1
8	G552 7153	DC Solenoid	1
9	A259 6754	Bushing - 6 6mm	3
10	G552 7225	Lower Right Transport Guide Plate	1
11	G552 7064	Transport Roller	1
12	G552 7033	Bushing - 6mm	1
13	G552 7361	Lever Spring	1
14	5053 0447	Bushing - 6mm	3

Index No.	Part No.	Description	Q'ty Per Assembly
101	0805 0089	Retaining Ring - M4	
102	0313 0040B	Philips Pan Head Screw - M3x4	
103	0450 3008B	Tapping Screw - M3x8	

3.DUPLEX UNIT 3 (G552)

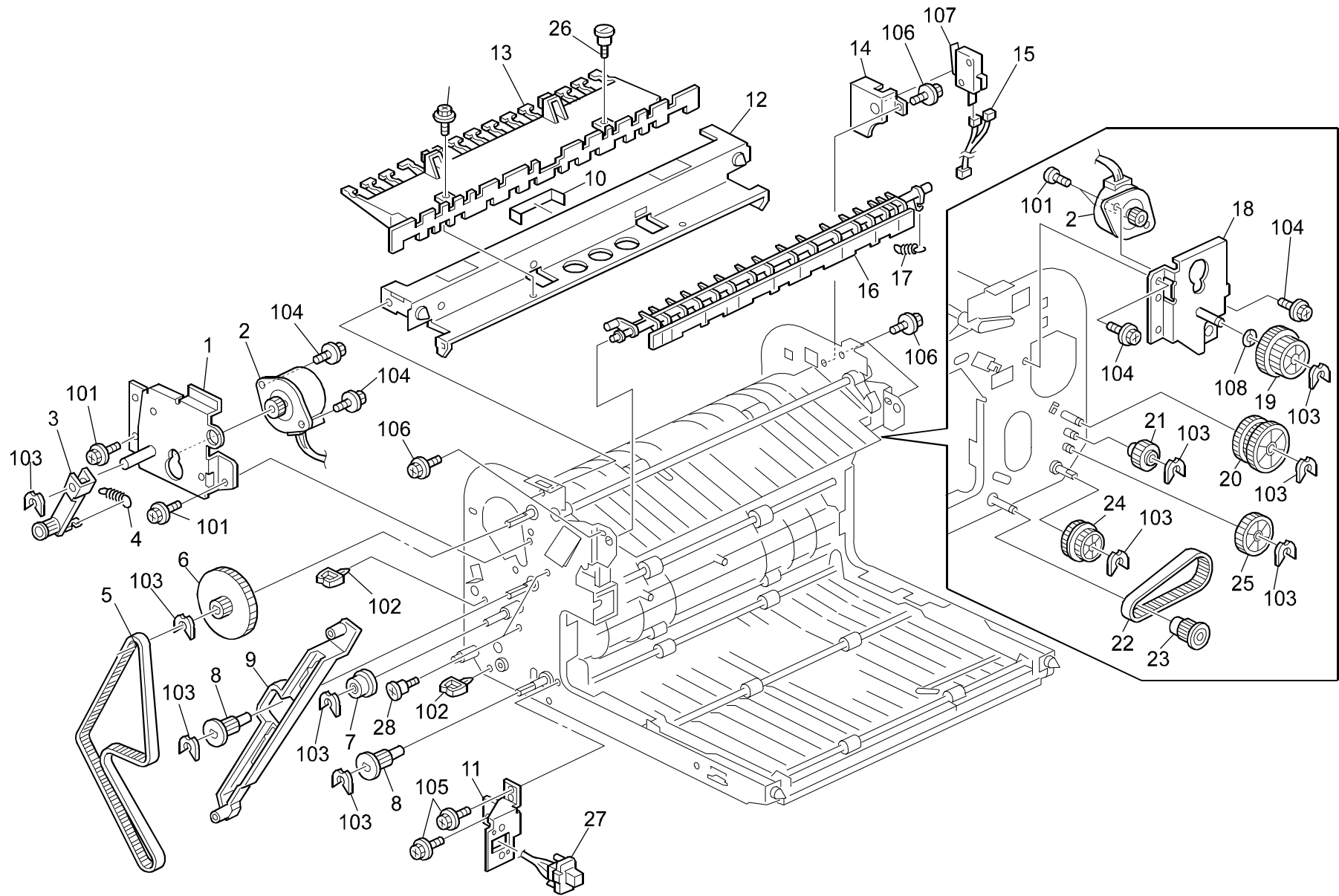

3.DUPLEX UNIT 3 (G552)

Index No.	Part No.	Description	Q'ty Per Assembly
1	G552 7030	Motor Bracket	1
2	G552 7008	Stepping Motor - DC24V	2
3	G552 7038	Tightener	1
4	G552 7363	Tightener Spring	1
5	G552 7022	Timing Belt	1
6	G552 7010	Pulley - 100Z	1
7	G552 7015	Idle Roller	1
8	G552 7011	Pulley - 16Z	1
9	G552 7335	Link	1
10	G552 7316	Lever Guide	1
11	G552 7229	Connector Bracket	1
12	G552 7333	Upper Stay	1
13	G552 7302	Upper Guide Plate	1
14	G552 7370	Switch Cover	1
15	G552 7914	Interlock Switch Harness	1
16	G552 7151	Fork Gate	1
17	G552 7362	Fork Gate Spring	1
18	G552 7140	Motor Bracket	1
19	G552 7114	Gear - 35Z	1
20	G552 7147	Gear - 28Z	1
21	G552 7144	Gear - 17Z	1
22	G552 7141	Timing Belt	1
23	G552 7143	Pulley - 18Z	1
24	G552 7142	Pulley - 28Z	1
25	G552 7149	Gear - 30Z	1
26	AA14 3716	Stepped Screw	1
	G004 4635	X/X MB4	
27	G552 7913	Harness	1
28	G004 4635	Stepped Screw - M3 MB4 ADDED	2

Index No.	Part No.	Description	Q'ty Per Assembly
101	0802 5276	Tapping Screw With Washer - M3x6	
102	1105 0199	Clamp MB4 ADDED	
103	0805 0089	Retaining Ring - M4	
104	0453 3005B	Binding Self Tapping Screw - 3x5	
105	0451 3008B	Tapping Screw - M3x8	
106	0451 3006B	Tapping Screw - M3x6	
107	1204 2521	Micro Switch	
108	0807 4087	Washer - 6.3*14 : T=0	
109	1105 0229	MB4 DELETED	
110	0313 0040B	MB4 DELETED	

4.DUPLEX UNIT 4 (G552)

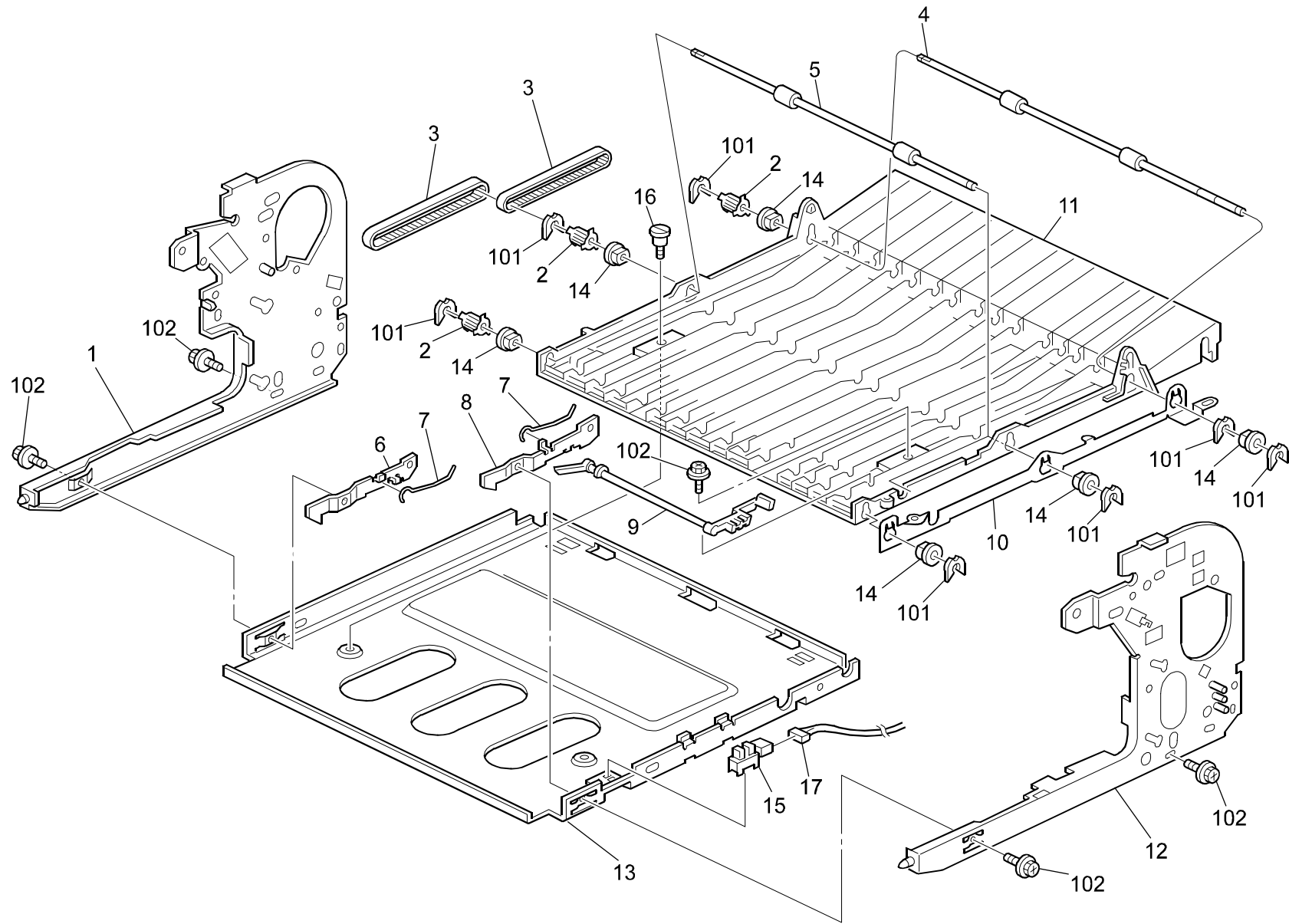

4.DUPLEX UNIT 4 (G552)

Index No.	Part No.	Description	Q'ty Per Assembly
1	G552 7312	Front Side Plate	1
2	G552 7217	Pulley - 18Z	3
3	G552 7233	Timing Belt	2
4	G552 7220	Transport Roller	1
5	G552 7221	Transport Roller	2
6	G552 7398	Front Lever	1
7	G552 7228	Lever Spring	2
8	G552 7399	Rear Lever	1
9	G552 7234	Feeler	1
10	G552 7232	Grounding Plate	1
11	G552 7240	Lower Guide Plate	1
	G552 7222	X/O MB2	
12	G552 7311	Rear Side Plate	1
13	G552 7318	Bottom Plate	1
14	5053 0447	Bushing - 6mm	6
15	AW02 0119	Photointerruptor - LG-24811	1
16	G012 4617	Stepped Screw - M3	1
17	G552 7917	Exit Sensor Harness	1



Index No.	Part No.	Description	Q'ty Per Assembly
101	0805 0089	Retaining Ring - M4	
102	0451 3006B AA14 3716	Tapping Screw - M3x6 X/X MB4	

Parts Index

Parts Index

Part No.	Description	Page and Index No.
G552 2300	Decal - Misfeed	3 - 15
G552 7008	Stepping Motor - DC24V	7 - 2
G552 7010	Pulley - 100Z	7 - 6
G552 7011	Pulley - 16Z	7 - 8
G552 7013	Decal - Guide Plate	3 - 24
G552 7015	Idle Roller	7 - 7
G552 7022	Timing Belt	7 - 5
G552 7025	Sensor Bracket	3 - 11
G552 7030	Motor Bracket	7 - 1
G552 7033	Bushing - 6mm	5 - 12
G552 7038	Tightener	7 - 3
G552 7039	Upper Sensor Bracket	5 - 3
G552 7050	Photointerruptor	3 - 8
G552 7050	Photointerruptor	5 - 4
G552 7064	Transport Roller	5 - 11
G552 7066	Transport Roller	5 - 6
G552 7114	Gear - 35Z	7 - 19
G552 7130	Guide Plate	5 - 2
G552 7140	Motor Bracket	7 - 18
G552 7141	Timing Belt	7 - 22
G552 7142	Pulley - 28Z	7 - 24
G552 7143	Pulley - 18Z	7 - 23
G552 7144	Gear - 17Z	7 - 21
G552 7147	Gear - 28Z	7 - 20
G552 7149	Gear - 30Z	7 - 25
G552 7151	Fork Gate	7 - 16
G552 7153	DC Solenoid	5 - 8
G552 7217	Pulley - 18Z	9 - 2
G552 7219	Upper Right Transport Guide Plate	5 - 5
G552 7220	Transport Roller	9 - 4
G552 7221	Transport Roller	9 - 5
G552 7222	X/O MB2	9 - 11
G552 7225	Lower Right Transport Guide Plate	5 - 10
G552 7228	Lever Spring	9 - 7
G552 7229	Connector Bracket	7 - 11

Part No.	Description	Page and Index No.
G552 7232	Grounding Plate	9 - 10
G552 7233	Timing Belt	9 - 3
G552 7234	Feeler	9 - 9
G552 7235	Left Guide Cover	3 - 2
G552 7240	Lower Guide Plate	9 - 11
G552 7283	Left Guide Plate	3 - 3
G552 7285	Driven Roller	3 - 5
G552 7292	Spring Plate - Lower Vertical Transport	3 - 17
G552 7293	Spring Plate - Driven	3 - 21
G552 7302	Upper Guide Plate	7 - 13
G552 7303	Base Cover	3 - 23
G552 7311	Rear Side Plate	9 - 12
G552 7312	Front Side Plate	9 - 1
G552 7316	Lever Guide	7 - 10
G552 7318	Bottom Plate	9 - 13
G552 7327	Fork Gate Release	5 - 7
G552 7328	Right Guide Plate	3 - 4
G552 7333	Upper Stay	7 - 12
G552 7334	Release Lever	3 - 7
G552 7335	Link	7 - 9
G552 7343	Cover	3 - 14
G552 7344	Lever	3 - 13
G552 7348	Rear Cover	3 - 22
G552 7354	Driven Roller	3 - 26
G552 7356	Left Guide	3 - 20
G552 7360	Driven Roller	3 - 25
G552 7361	Lever Spring	5 - 13
G552 7362	Fork Gate Spring	7 - 17
G552 7363	Tightener Spring	7 - 4
G552 7364	Shaft	3 - 6
G552 7365	Spring Plate - Upper Vertical Transport	3 - 18
G552 7366	Spring Plate - Vertical Transport	3 - 16
G552 7370	Switch Cover	7 - 14
G552 7387	Left Cover	5 - 1
G552 7389	Front Cover	3 - 1

Part No.	Description	Page and Index No.
G552 7391	Upper Cover	3 - 12
G552 7392	Cover Spring	3 - 19
G552 7398	Front Lever	9 - 6
G552 7399	Rear Lever	9 - 8
G552 7913	Harness	7 - 27
G552 7913	Harness	3 - 9
G552 7914	Interlock Switch Harness	7 - 15
G552 7915	Entrance Sensor Harness	3 - 30
G552 7916	Grounding Wire Harness	3 - 27
G552 7917	Exit Sensor Harness	9 - 17
G552 7931	X/O MB3	3 - 10
G552 7965	Main Control Board (CHN)	3 - 10
G552 7971	Main Control Board (EU/NA) MB4 ADDED	3 - 10

Part No.	Description	Page and Index No.
A259 6754	Bushing - 6 6mm	5 - 9
G004 4635	X/X MB4	7 - 26
G004 4635	Stepped Screw - M3 MB4 ADDED	7 - 28
G012 4617	Stepped Screw - M3	9 - 16

Part No.	Description	Page and Index No.
AA14 3287	Stepped Screw - M3	3 - 28
AA14 3716	Stepped Screw	7 - 26
AA14 3716	X/X MB4	9 - 102
AW02 0119	Photointerruptor - LG-24811	9 - 15

Part No.	Description	Page and Index No.
0313 0040B	MB4 DELETED	7 - 110
0313 0040B	Phillips Pan Head Screw - M3x4	5 - 102
0450 3008B	Tapping Screw - M3x8	3 - 102
0450 3008B	Tapping Screw - M3x8	5 - 103
0451 3006B	Tapping Screw - M3x6	3 - 101
0451 3006B	Tapping Screw - M3x6	7 - 106
0451 3006B	Tapping Screw - M3x6	9 - 102
0451 3008B	Tapping Screw - M3x8	7 - 105
0453 3005B	Binding Self Tapping Screw - 3x5	7 - 104
0802 5276	Tapping Screw With Washer - M3x6	7 - 101
0805 0089	Retaining Ring - M4	7 - 103
0805 0089	Retaining Ring - M4	5 - 101
0805 0089	Retaining Ring - M4	9 - 101
0807 4087	Washer - 6.3*14 : T=0	7 - 108
1105 0199	Clamp MB4 ADDED	7 - 102
1105 0229	MB4 DELETED	7 - 109
1204 2521	Micro Switch	7 - 107

Part No.	Description	Page and Index No.
5053 0447	Bushing - 6mm	5 - 14
5053 0447	Bushing - 6mm	9 - 14
5447 2681	Snap Ring	3 - 29

Part No.	Description	Page and Index No.